

**Dimensions**

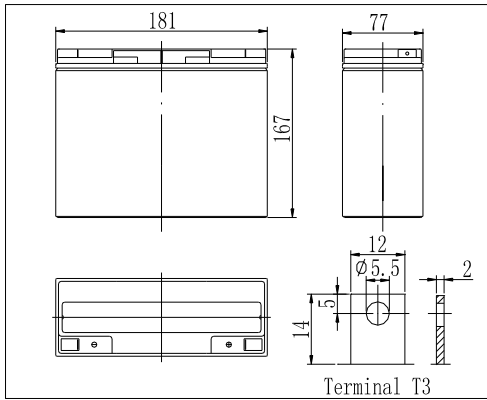

**The Relationship for Open Circuit Voltage and Residual Capacity (25°C)**

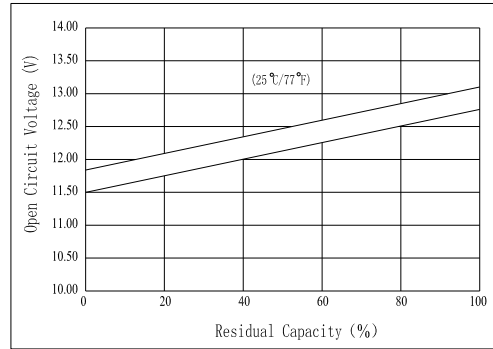

**Specifications**

Nominal Voltage		12 V
Capacity(20HR, 25°C)		20 Ah
Dimension	Length	181mm (7.13inch)
	Width	77mm (3.03inch)
	Height	167mm (6.57inch)
	Total Height	167mm (6.57inch)
Approx. Weight		5.8kg (12.8lbs)
Internal resistance (Fully charged, 25°C)		Approx. 15m Ω
Capacity affected by temperature (20HR)	40°C	102%
	25°C	100%
	0°C	85%
	-15°C	65%
Self-discharge (25°C)	3 month	Remaining Capacity: 91%
	6 month	Remaining Capacity: 82%
	12 month	Remaining Capacity: 65%
Nominal operating temperature		25°C ±3°C(77°F ±5°F)
Operating temperature range		-15°C ~50°C (5°F ~122°F )
Float charging voltage(25°C)		13.60 to 13.80V
Cyclic charging voltage(25°C)		14.50 to 14.90V
Maximum charging current		6A
Terminal material		Copper
Maximum discharge current		300A(5 sec.)

**Charging Characteristics(25°C)**

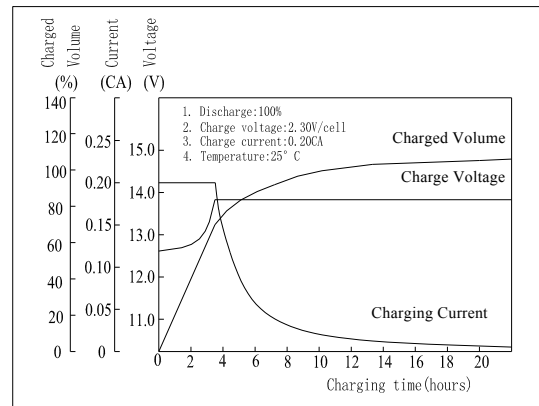

**Cycle Life(25°C)**

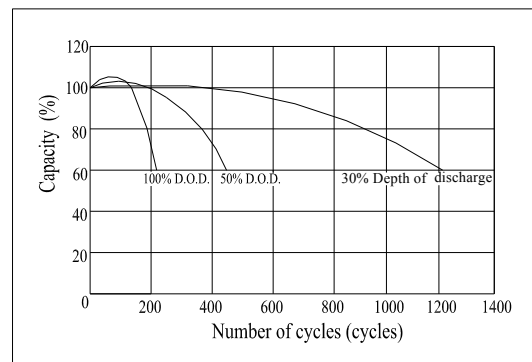

Note: Floating life at 20°C designed for 3 to 5 years.

- ◆ Absorbent glass mat technology;
- ◆ Recognized by UL & CE;
- ◆ ABS container.

**Constant Current Discharge Characteristics (A, 25°C)**

F.V/TIME	5min	10min	15min	30min	60min	3h	5h	10h	20h
9.60V	76.0	48.0	38.0	22.0	13.0	5.08	3.45	1.87	1.02
10.2V	72.2	45.6	36.5	21.1	12.5	5.00	3.40	1.85	1.01
10.8V	67.9	42.9	34.7	20.1	11.9	4.90	3.33	1.84	1.00

**Constant Power Discharge Characteristics (Watt, 25°C)**

F.V/TIME	5min	10min	15min	30min	60min	3h	5h	10h	20h
9.60V	848	541	433	252	151	60.3	41.2	22.4	12.2
10.2V	806	514	416	242	145	59.4	40.6	22.2	12.1
10.8V	757	484	395	230	137	58.2	39.8	22.2	12.0